

SPECIFICATIONS:

01. Input voltage (+VSS) range is 4.5 to 16 volts DC, current draw 10mA.
02. Output square wave 0 to +VSS, 4 pulses per tang revolution, Impedance is 2.7K ohm.
03. Unit is connected to the Mechanical Tachometer Drive port on engine.
04. Standard Tang, UMA PN: 11022, is used to adapt TSU to engine, others available.
05. Tang P/N 11022 will shear at a maximum of 35 In. Lbs. of torque.
06. Less than 5 In. lbs. of torque required to maintain tang speed up to 2000 RPM
07. Oil impregnated, self lubricating, wear resistant sleeve bearing.
08. Rotation CW or CCW
09. Signal Ground not connected to case.
10. Printed circuit board is conformal coated (MIL-1-46058C Type SR or equivalent).
11. Weight is 0.2 pounds.
12. Unit is to be used in conjunction with UMA P/N: 1D6 wiring harness

Specification Drawing

| | | | | | | | | | | | | | |
|-----|-----|-------------|----|------|-----|----------------------------|--------|--|--------------------------|---------|----------|-------|--------|
| | | | | | | TOLERANCES EXCEPT AS NOTED | | UMA Inc, 260 Main St. Dayton, VA 22821 | | | | | |
| | | | | | | .XX | ±0.01 | SCALE | 1 : 1 | DATE: | 02/04/98 | SHEET | 1 of 1 |
| | | | | | | .XXX | ±0.005 | SUPPLIER COMPLETE | <input type="checkbox"/> | DRAW BY | C.B.H. | | |
| | | | | | | ANGULAR | ±1° | DESCRIPTION TSO'd TACHOMETER ROTATING SENDING UNIT | | | | | |
| ECO | REV | DESCRIPTION | DR | DATE | APP | | | APP | PART# | | T1A3-4 | REV | IR |

MATERIAL:

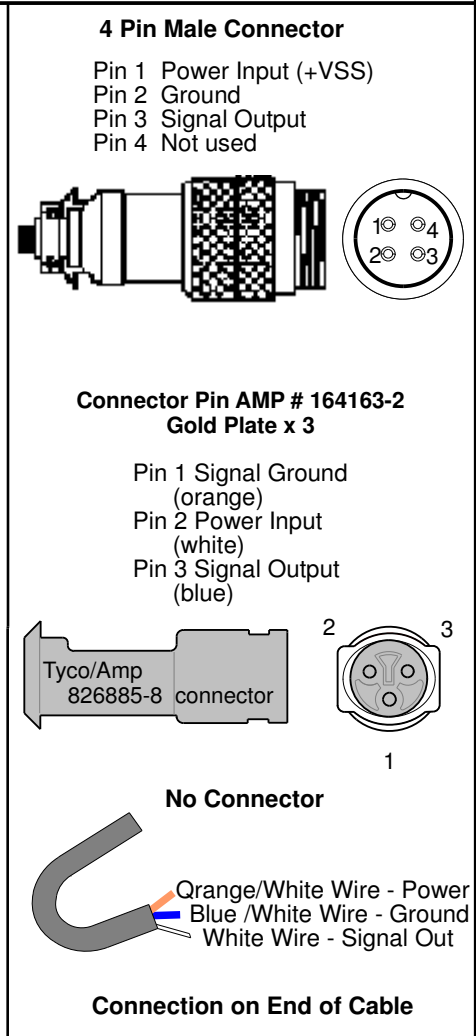
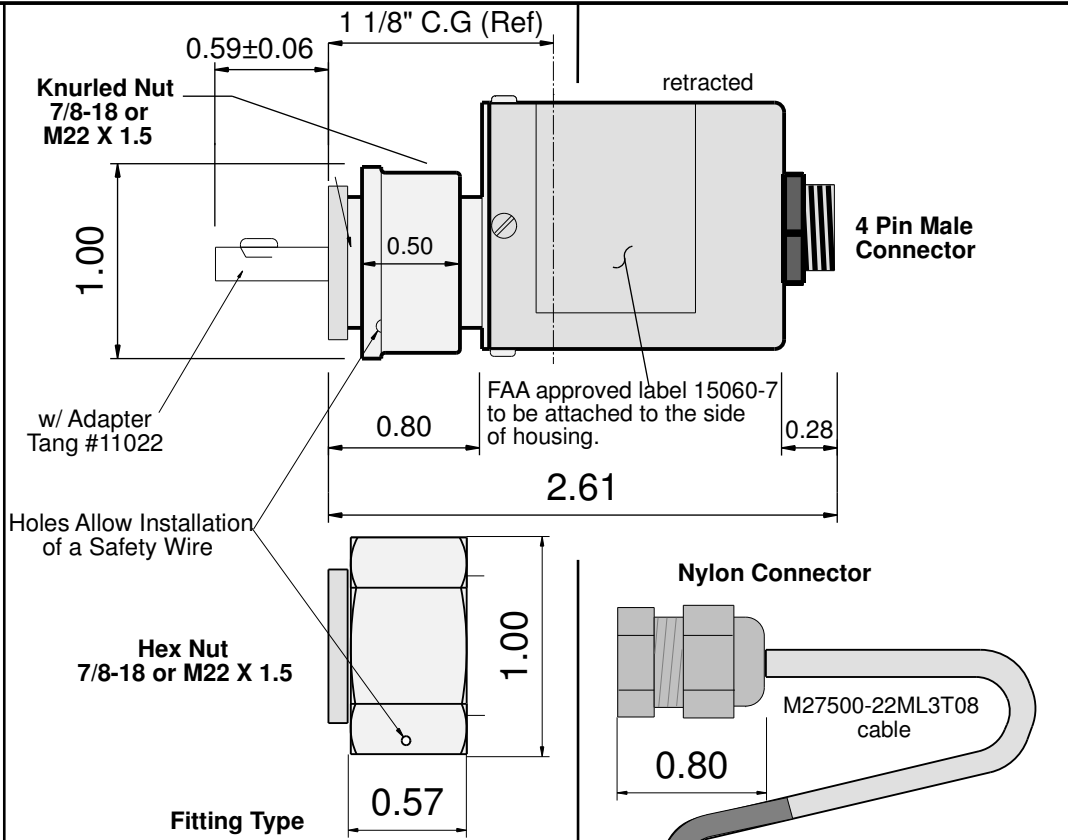
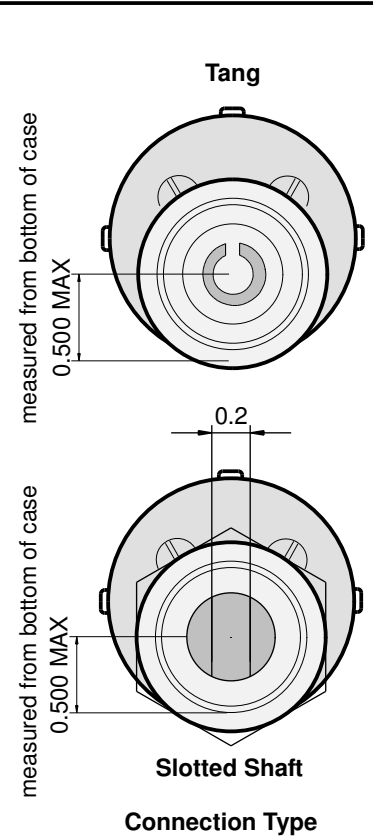

- SPECIFICATIONS:**
01. Input voltage (+VSS) range is 4.5 to 16 volts DC, current draw 10mA.
 02. Output square wave 0 to +VSS, 2 or 4 pulses per tang revolution (dependent on unit purchased), Impedance is 2.7K ohm.
 03. Unit is connected to the Mechanical Tachometer Drive port on engine.
 04. Standard Tang, UMA PN: 11022, is used to adapt TSU to engine, others available.
 05. Tang P/N 11022 will shear at a maximum of 35 In. Lbs. of torque.
 06. Less than 5 In. lbs. of torque required to maintain tang speed up to 2000 RPM
 07. Oil impregnated, self lubricating, wear resistant sleeve bearing.
 08. Rotation CW or CCW
 09. Signal Ground not connected to case.
 10. Printed circuit board is conformal coated (MIL-1-46058C Type SR or equivalent).
 11. Weight is 0.2 pounds.
 12. Unit is to be used in conjunction with UMA P/N: 1D6 wiring harness

Specification Drawing

| ECO | REV | DESCRIPTION | DR | DATE | APP |
|---------|-----|---------------------------------|-----|----------|-----|
| 2019015 | B | Add [] to P/N, New Magnet Mfg. | REM | 8/19/19 | ShM |
| 2018013 | A | Added short body TSU | REM | 06/15/18 | ShM |

| TOLERANCES EXCEPT AS NOTED | |
|----------------------------|--------|
| .XX | ±0.05 |
| .XXX | ±0.010 |
| ANGULAR | ±1° |

| | | | |
|---|--------------------------------|--------------|--|
| UMA Inc, 260 Main St. Dayton, VA 22821 | | | |
| SCALE 1:1 | DATE: 9-7-17 | SHEET 1 of 3 | |
| SUPPLIER COMPLETE <input type="checkbox"/> | DRAW BY R. E. M. | | |
| DESCRIPTION TSO'd TACHOMETER ROTATING SENDING UNIT & TSO'd SHORT, TACHOMETER ROTATING SENDING UNIT | | | |
| APP | PART# T[]A[] []-[]-[]-[] | REV B | |

MATERIAL:

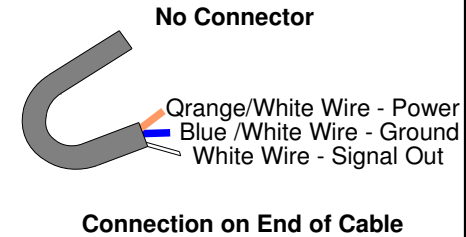
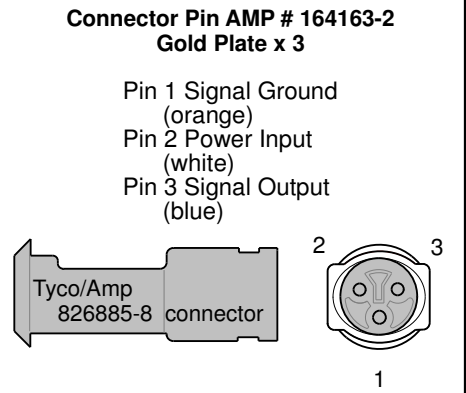
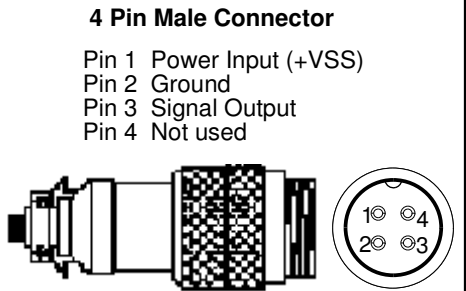
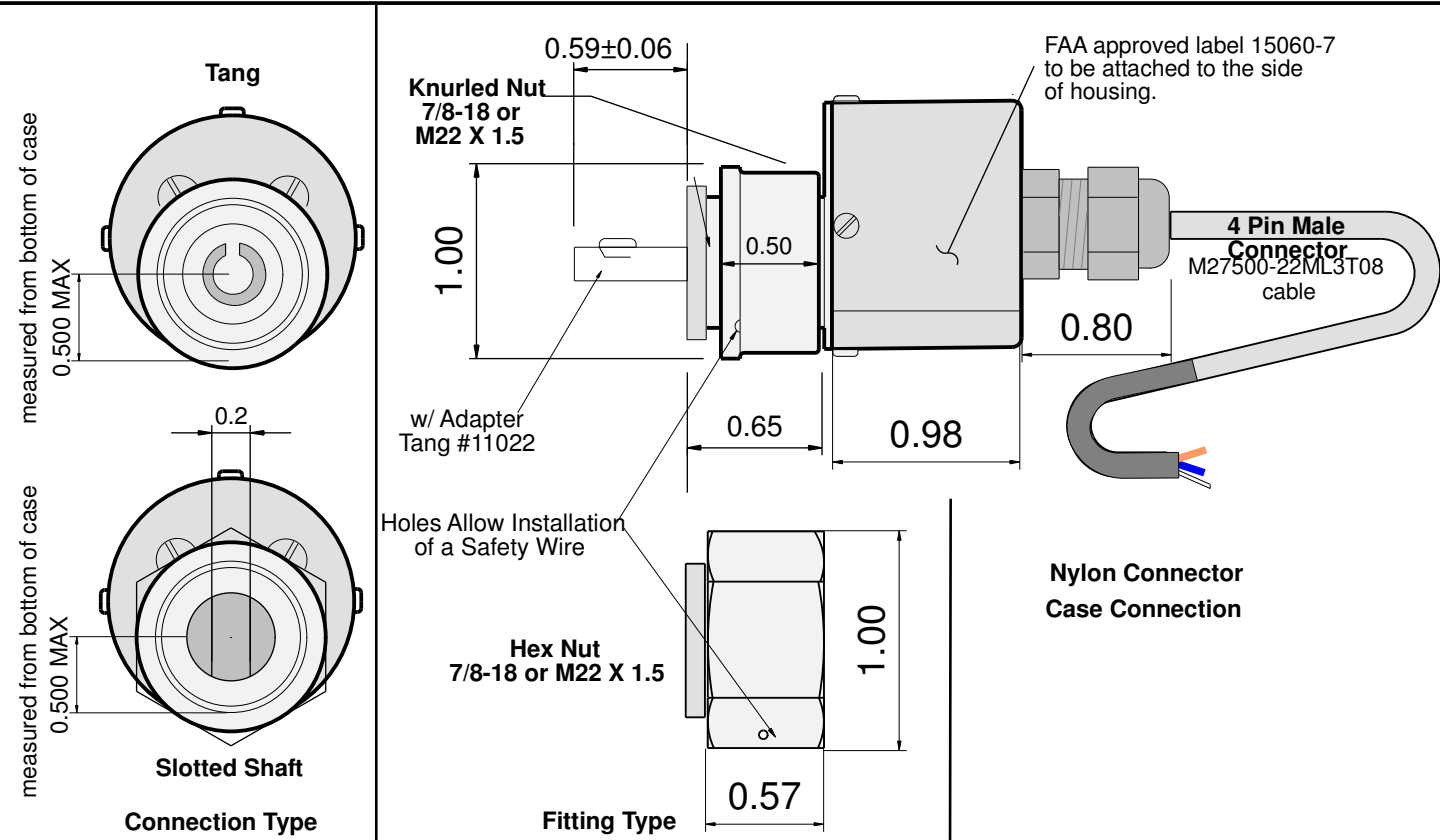

SPECIFICATIONS:

01. Input voltage (+VSS) range is 4.5 to 16 volts DC, current draw 10mA.
02. Output square wave 0 to +VSS, 2 or 4 pulses per tang revolution (dependent on unit purchased), Impedance is 2.7K ohm.
03. Unit is connected to the Mechanical Tachometer Drive port on engine.
04. Standard Tang, UMA PN: 11022, is used to adapt TSU to engine, others available.
05. Tang P/N 11022 will shear at a maximum of 35 In. Lbs. of torque.
06. Less than 5 In. lbs. of torque required to maintain tang speed up to 2000 RPM
07. Oil impregnated, self lubricating, wear resistant sleeve bearing.
08. Rotation CW or CCW
09. Signal Ground not connected to case.
10. Printed circuit board is conformal coated (MIL-1-46058C Type SR or equivalent).
11. Weight is 0.2 pounds.
12. Unit is to be used in conjunction with UMA P/N: 1D6 wiring harness

Specification Drawing

| | | | | | | | | | | |
|---------|-----|---------------------------------|-----|----------|-----|----------------------------|--|--|-------------------------------|--------------|
| | | | | | | TOLERANCES EXCEPT AS NOTED | | UMA Inc, 260 Main St. Dayton, VA 22821 | | |
| | | | | | | .XX ±0.05 | SCALE 1:1 | | DATE: 6/15/18 | SHEET 2 of 3 |
| | | | | | | .XXX ±0.010 | SUPPLIER COMPLETE <input type="checkbox"/> | DRAW BY R. E. M. | | |
| | | | | | | ANGULAR ±1° | DESCRIPTION TSO'd TACHOMETER ROTATING SENDING UNIT & TSO'd SHORT, TACHOMETER ROTATING SENDING UNIT | | | |
| 2019015 | B | Add [] to P/N, New Magnet Mfg. | REM | 8/19/19 | ShM | APP | | PART# | T [] A [] [] - [] [] [] | REV B |
| 2018013 | A | Added short body TSU | REM | 06/15/18 | ShM | | | | | |
| ECO | REV | DESCRIPTION | DR | DATE | APP | | | | | |

MATERIAL:

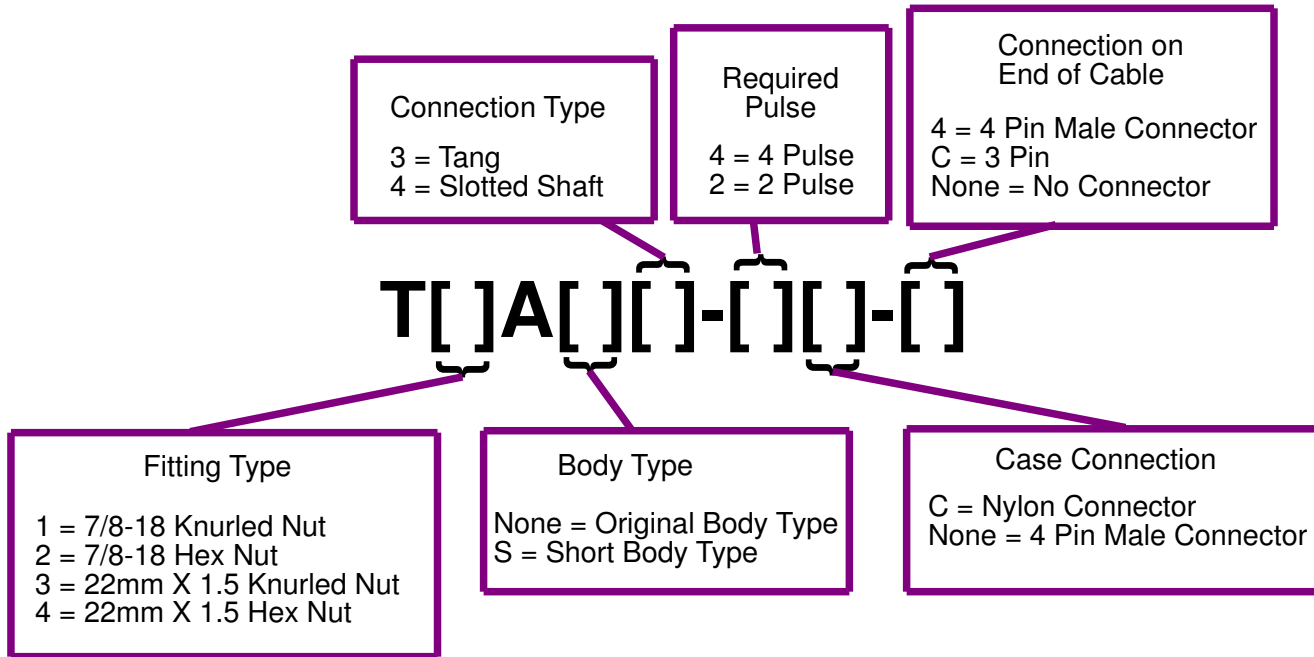

| | | | | | |
|---------|-----|---------------------------------|-----|----------|-----|
| | | | | | |
| | | | | | |
| | | | | | |
| 2019015 | B | Add [] to P/N, New Magnet Mfg. | REM | 8/19/19 | ShM |
| 2018013 | A | Added short body TSU | REM | 06/15/18 | ShM |
| ECO | REV | DESCRIPTION | DR | DATE | APP |

| |
|----------------------------|
| TOLERANCES EXCEPT AS NOTED |
| .XX |
| .XXX |
| ANGULAR |

| | | |
|--|------------------|--------------|
| UMA Inc, 260 Main St. Dayton, VA 22821 | | |
| SCALE | DATE: 9/7/17 | SHEET 3 of 3 |
| SUPPLIER COMPLETE <input type="checkbox"/> | DRAW BY REM | |
| DESCRIPTION TSO'd TACHOMETER ROTATING SENDING UNIT & TSO'd SHORT, TACHOMETER ROTATING SENDING UNIT | | |
| APP | PART# T[A][H][H] | REV B |