



2 1/4 INCH ELECTRONIC FUEL FLOW GAUGE

Installation Instructions:

Additional wire and fuses will be necessary for installation of unit.

1. Mount gauge in desired location in aircraft's instrument panel.

CAUTION: Use extreme caution when working around fuel. Work in a well ventilated area and keep all hot tools and materials away from fuel. Do not smoke or use an open flame.

2. Install fuel flow sender in accordance with directions included.

IMPORTANT: Make sure to route all wires and fuel lines away from sources of heat and moving parts.

IMPORTANT: After sender installation, check for fuel leaks before flight.

1. Route **Black** wire (ground) from sender to **Black** wire on the gauge, **White** wire from sender to **White** wire on the gauge, and **Red** wire from sender to **Yellow** wire on the gauge. Use #24 AWG minimum, shielded wire.
2. Connect a wire(+) from switched side of master switch to **Red** wire on the gauge. Use a 1 amp inline fuse or route through a breaker. Connect **Black** wire from the gauge to a suitable aircraft ground. Ensure this ground is connected to airframe and engine. Use #24 AWG size or larger wire for all connections.

Specifications:

Description:	Remote-indicating electronic fuel flow instrument
Power Req.	11- 28 Volts DC 150 mA (Maximum)
Weight:	Gauge - 4 oz. Sender - 6 oz.
Sender Type:	Electronics International FT-60

DIMENSIONAL DIAGRAM

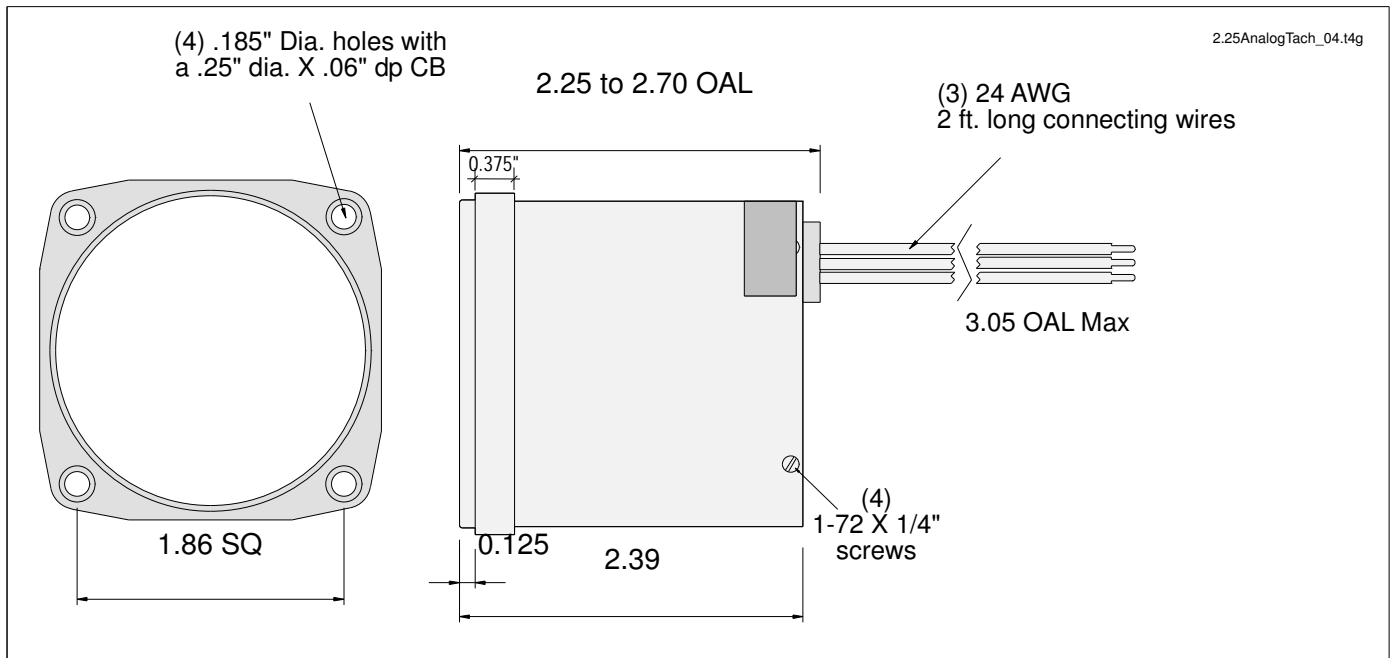

Warranty

UMA, Inc. warrants all products to be free from defects in material and workmanship under normal use and operation. UMA does not warrant any product which has been damaged as the result of accident, abuse, negligence, improper operational voltage, lightning, fire, flood, or other acts of nature. Any indication that the unit has been opened can void warranty. Under no circumstances shall UMA be liable for any loss or damage, direct, consequential or incidental, arising from the use of or inability to use this product.

This warranty is limited to the repair or replacement, at the manufacturer's option, of any product or part thereof, which has been returned to UMA within the specified warranty period, and which after examination shall disclose to the customer service department's satisfaction that the product is defective. Transportation to the factory or authorized service center must be prepaid; the product after repair or replacement will be returned at the expense of the dealer or end customer. This warranty does not apply to any product or integral part thereof, which has been altered or serviced by other than the manufacturer or authorized service center.

The warranty period is twelve (12) months to the user.

This warranty supersedes all other warranties either expressed or implied and shall be governed and executed under the laws of the Commonwealth of Virginia, USA